

**1** ELEVATION  
Scale: 1/2" = 1'-0"

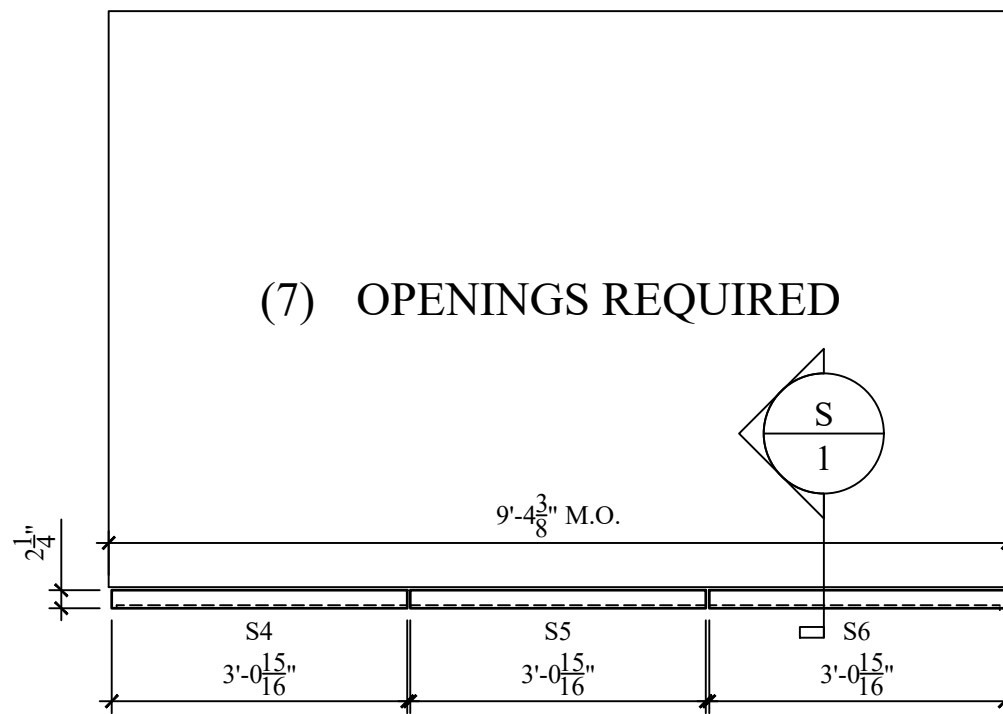

**2** ELEVATION  
Scale: 1/2" = 1'-0"

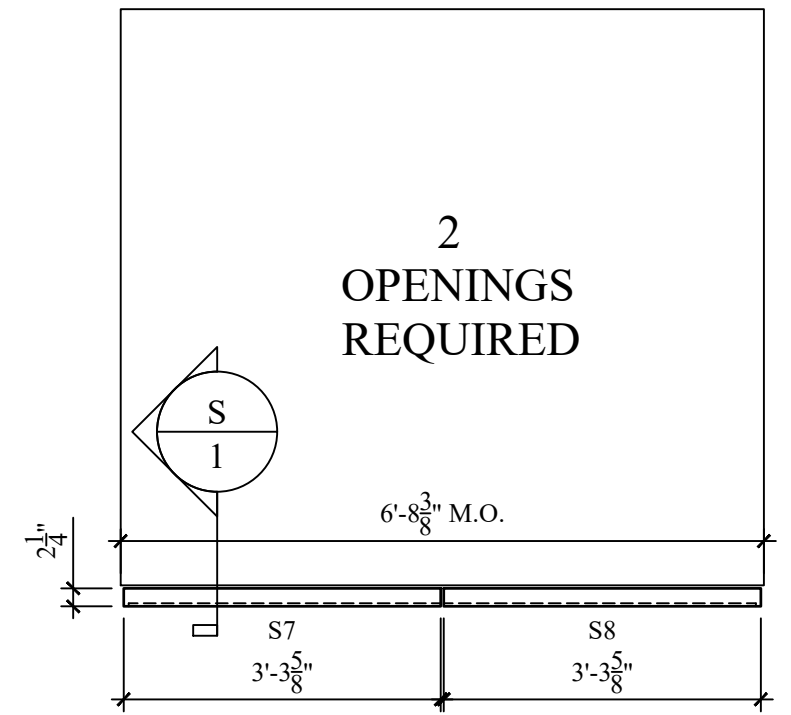

**3** ELEVATION  
Scale: 1/2" = 1'-0"

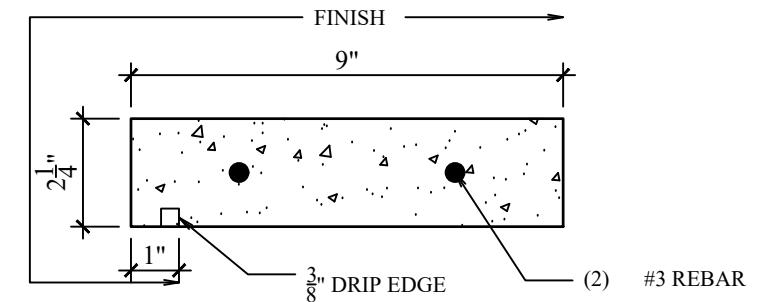

**S** SECTION  
Scale: 3" = 1'-0"

**IMPORTANT NOTICE**  
THIS SHOP DRAWING REPRESENTS OUR INTERPRETATION OF THE ARCHITECT'S PLANS & SPECIFICATIONS, AND OUR CONTRACT REQUIREMENTS FOR THE PROJECT. PRIOR TO FABRICATION OF ANY STONE FOR THIS PROJECT, ALL METHODS OF CONSTRUCTION AND EXISTING CONDITIONS MUST BE CHECKED AND CORRECTED OR APPROVED BY OUR CUSTOMER. NO PRECAST WILL BE SCHEDULED FOR FABRICATION UNTIL WE HAVE BEEN NOTIFIED IN WRITING BY OUR CUSTOMER THAT OUR SHOP DRAWINGS HAVE BEEN APPROVED FOR FABRICATION. APPROVAL DELAY RESULTS IN FABRICATION & DELIVERY DELAY. ANY STONE FABRICATED IN ACCORDANCE WITH APPROVED SHOP DRAWINGS THAT DOES NOT FIT JOB CONDITIONS WILL BE REMADE AND SHIPPED TO THE JOB ONLY AT OUR CUSTOMER'S EXPENSE, AND ONLY AFTER RECEIPT OF SIGNED CHANGE ORDER TO COVER ADDITIONAL EXPENSES. WE ASSUME NO RESPONSIBILITY FOR CUTTING OF OUR STONE TO ACCOMMODATE OTHER TRADES UNLESS ADEQUATE INFORMATION IS PROVIDED ON OUR SHOP DRAWINGS. WE ASSUME NO RESPONSIBILITY AS TO MEASUREMENTS OR DETAILS AFFECTING ANY WORK BUT OUR OWN.

1. DIMENSIONS ON ALL SHEETS ARE ACTUAL, NOT NOMINAL.
2. DO NOT SCALE SHOP DRAWINGS.
3. SEE PROJECT DRAWINGS FOR ADDITIONAL ITEMS EMBEDDED IN PRECAST CONCRETE.
4. ALL JOINTS TO BE 3/8" U.O.N. ON SHOP DRAWINGS.
5. WESTBROOK C.B. IS NOT RESPONSIBLE FOR PIECES THAT NEED TO BE FIELD CUT.
6. PLEASE VERIFY IF JOINTS AT LOCATIONS SHOWN ARE ACCEPTABLE. WESTBROOK C.B. WILL COORDINATE.
7. WESTBROOK C.B. IS NOT RESPONSIBLE FOR LOOSE HARDWARE/ ACCESSORIES UNLESS OTHERWISE NOTED.
8. WESTBROOK C.B. IS NOT RESPONSIBLE FOR FIELD VERIFICATIONS. WESTBROOK C.B. WILL COORDINATE.
9. FOAM INSERTS WILL BE LEFT IN THE DRIP & ANCHOR SLOTS TO AVOID BREAKAGE. FOAM MUST BE REMOVED AT THE JOB SITE BY INSTALLING ACTIVITY.

ALL PRECAST IS MANUFACTURED IN ACCORDANCE WITH ASTM 1364 SPECIFICATIONS.

REV.	DATE	DESCRIPTION	REV'D. BY:
<b>Westbrook Concrete Block</b>			
		439 SPENCER PLAINS ROAD WESTBROOK, CT 06498	T. 860.399.6201 WWW.WESTBROOKBLOCK.COM
SUBM. RECORD		JOB NAME: <b>77 CLARKSON AVE.</b>	
DATE	DESCRIPTION	LOCATION:	
5/14/2019	1st SUBM.	CONTRACTOR:	
	2nd SUBM.	ARCHITECT:	
	3rd SUBM.	SCALE: AS NOTED	DRAWN BY: <b>Mark Rogers Jr.</b>   CHK'D BY:
	4th SUBM.	DATE: 5/14/2019	SHEET SIZE: B
GENERAL CONTRACTOR TO CHECK ALL THE DIMENSIONS ON OUR DRAWINGS AND IN THE FIELD. WE ASSUME NO RESPONSIBILITY FOR GENERAL BUILDING DIMENSIONS.			WCB-19184   SHEET 1 OF 1

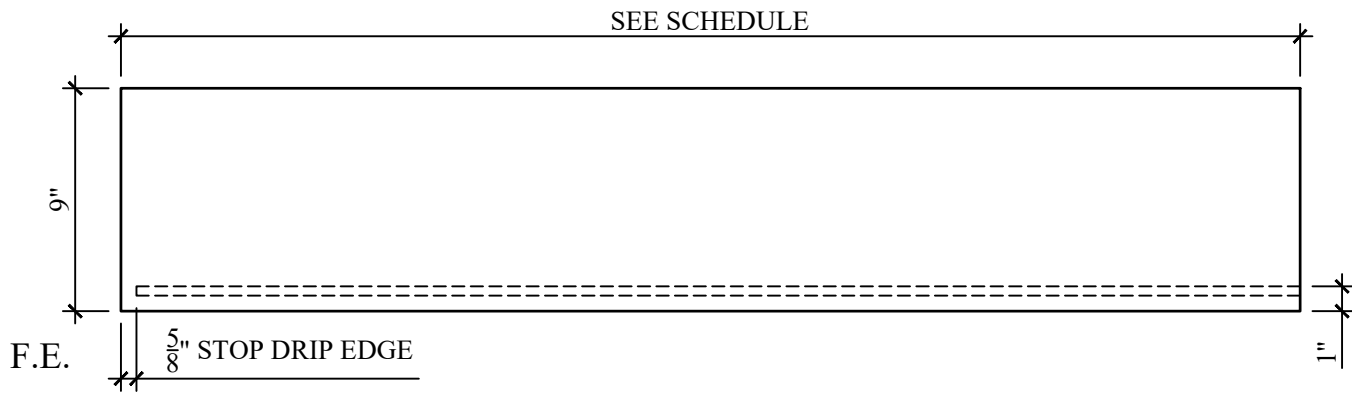

**1** PLAN VIEW  
Scale: 1-1/2" = 1'-0"

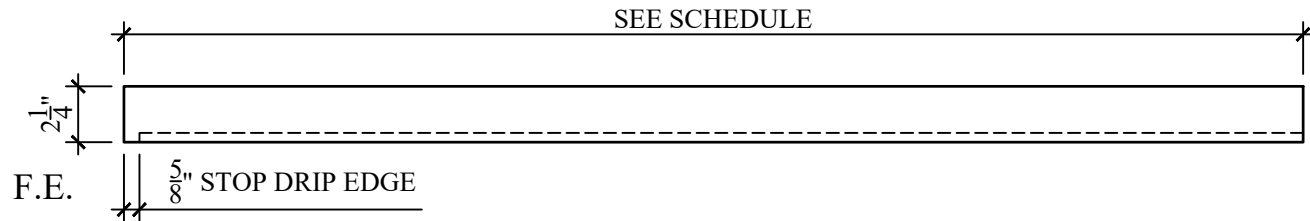

**2** ELEVATION  
Scale: 1-1/2" = 1'-0"

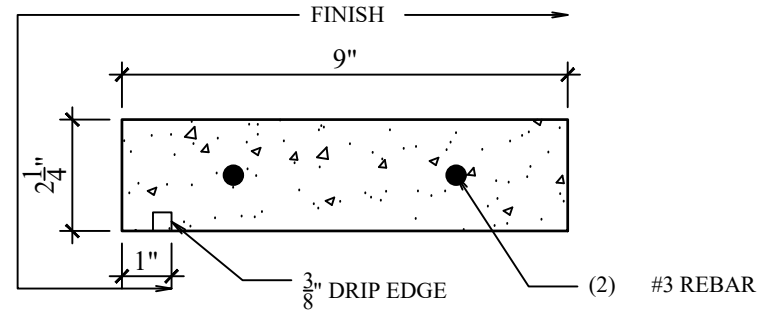

**S** SECTION  
Scale: 3" = 1'-0"

**NOTE:**  
**ALL STONE IN EXCESS OF 300 LBS SHALL REQUIRE LIFING INSERTS AS INDICATED.**

QTY	PC	LENGTH	WEIGHT (LBS)
13	S1	2'-7 <sup>5</sup> / <sub>8</sub> "	61.77
7	S4	3'-0 <sup>15</sup> / <sub>16</sub> "	72.14
2	S7	3'-3 <sup>5</sup> / <sub>8</sub> "	77.39

COLOR = 1/2 & 1/2-VL

REV.	DATE:	REV. BY:
		439 Spencer Plains Road t. 860.399.6201 Westbrook, CT 06498 www.westbrookblock.com
DATE: 5/30/2019		JOB NAME: <b>77 CLARKSON AVE.</b>
<b>WCB-19184</b>		DWN BY: M. Rogers Jr.

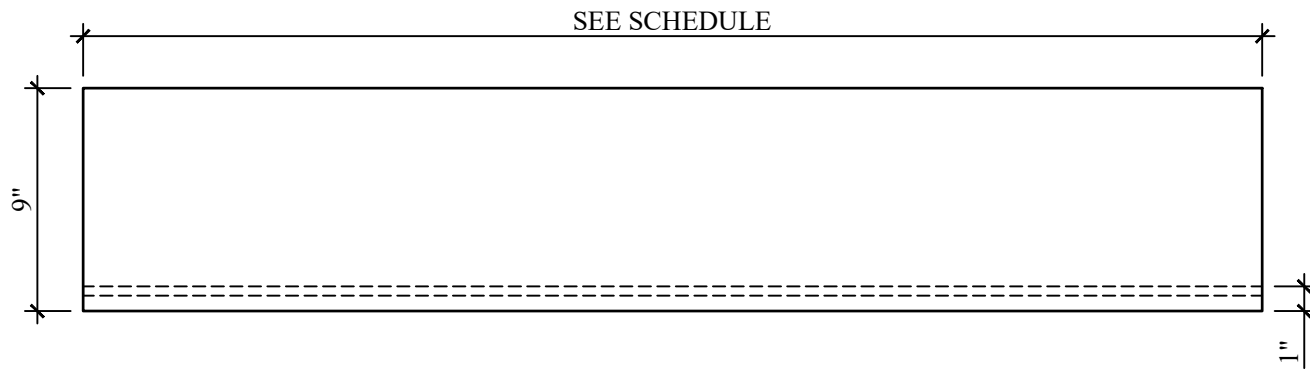

**1** PLAN VIEW  
Scale: 1-1/2" = 1'-0"

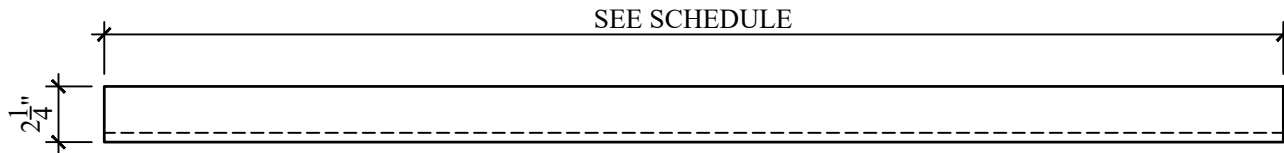

**2** ELEVATION  
Scale: 1-1/2" = 1'-0"

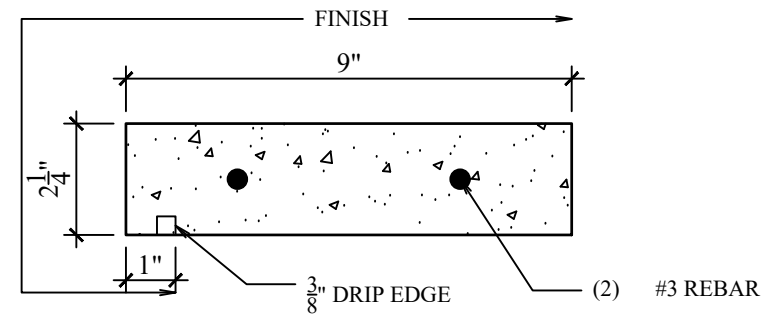

**S** SECTION  
Scale: 3" = 1'-0"

**NOTE:**  
ALL STONE IN EXCESS OF 300 LBS SHALL  
REQUIRE LIFING INSERTS AS INDICATED.

QTY	PC	LENGTH	WEIGHT (LBS)
13	S2	2'-7 <sup>5</sup> / <sub>8</sub> "	61.77
7	S5	3'-0 <sup>15</sup> / <sub>16</sub> "	72.14

COLOR = 1/2 & 1/2-VL

REV.	DATE:	REV. BY:
		439 Spencer Plains Road t. 860.399.6201 Westbrook, CT 06498 www.westbrookblock.com
DATE: 5/30/2019		JOB NAME: 77 CLARKSON AVE.
		<b>WCB-19184</b> DWN BY: M. Rogers Jr.

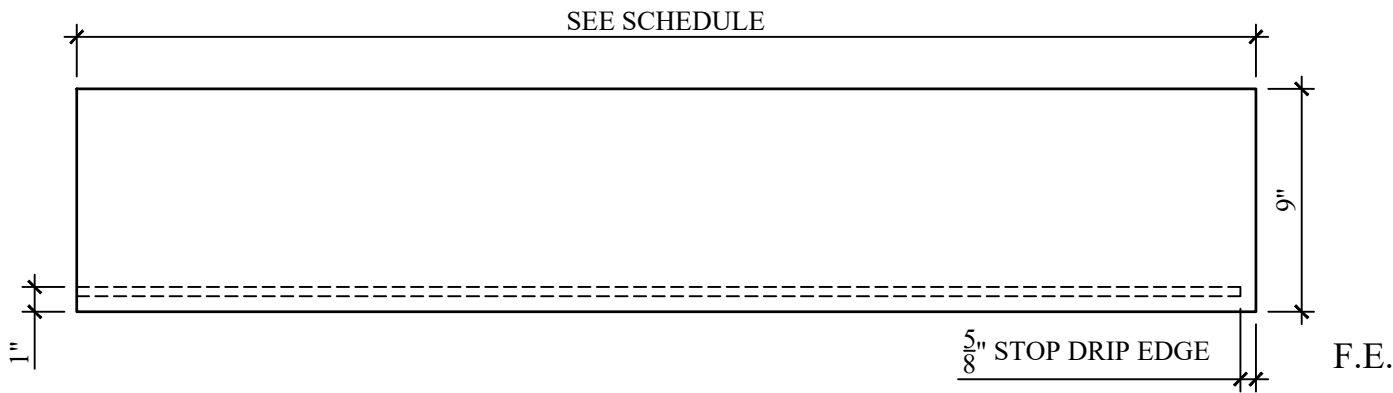

**1** PLAN VIEW  
Scale: 1-1/2" = 1'-0"

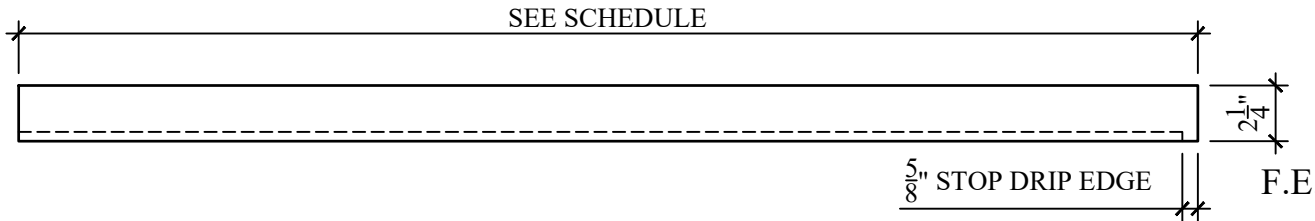

**2** ELEVATION  
Scale: 1-1/2" = 1'-0"

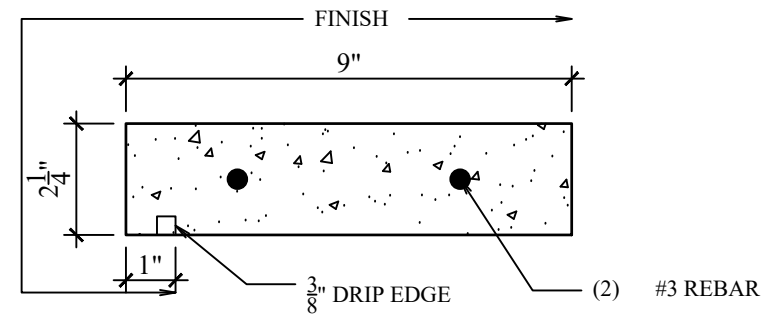

**S** SECTION  
Scale: 3" = 1'-0"

**NOTE:**  
ALL STONE IN EXCESS OF 300 LBS SHALL  
REQUIRE LIFING INSERTS AS INDICATED.

QTY	PC	LENGTH	WEIGHT (LBS)
13	S3	2'-7 <sup>5</sup> / <sub>8</sub> "	61.77
7	S6	3'-0 <sup>15</sup> / <sub>16</sub> "	72.14
2	S8	3'-3 <sup>5</sup> / <sub>8</sub> "	77.39

COLOR = 1/2 & 1/2-VL

REV.	DATE:	REV. BY:
		439 Spencer Plains Road t. 860.399.6201 Westbrook, CT 06498 www.westbrookblock.com
DATE: 5/30/2019		JOB NAME: 77 CLARKSON AVE.
		WCB-19184
		DWN BY: M. Rogers Jr.